

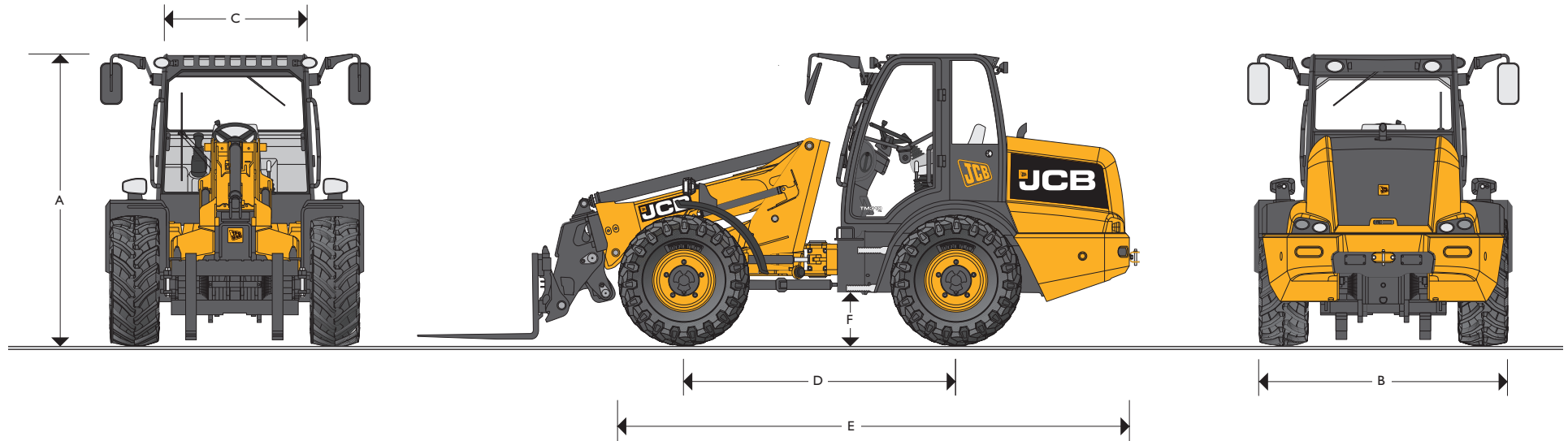

MAX. ENGINE POWER: 97kW 130hp / 108kW 145hp MAX. PAYLOAD: 3100kg (6832lb) MAX. LIFT HEIGHT: 5200mm (17ft 1in)



STATIC DIMENSIONS

Machine model	TM310/TM310S	Machine model	TM310/TM310S
	mm (ft-in)		
A Overall height	2695 (8-10)	Articulation angle	degrees ± 43°
B Overall width (over tyres)*	2344 (7-8)	Outside turn radius (over tyres)	mm (ft-in) 4382 (14-3)
C Inside width of cab	1267 (4-2)	Departure angle	degrees 28
D Wheelbase	2500 (8-2)	Weight	kg (lb) 8000 (17637)
E Overall length to front tyres	4715 (15-6)	Tyres	XMCL 460/70
F Ground clearance	444 (1-5)		

*Dependant upon tyre specification.



LIFT PERFORMANCE – TM310

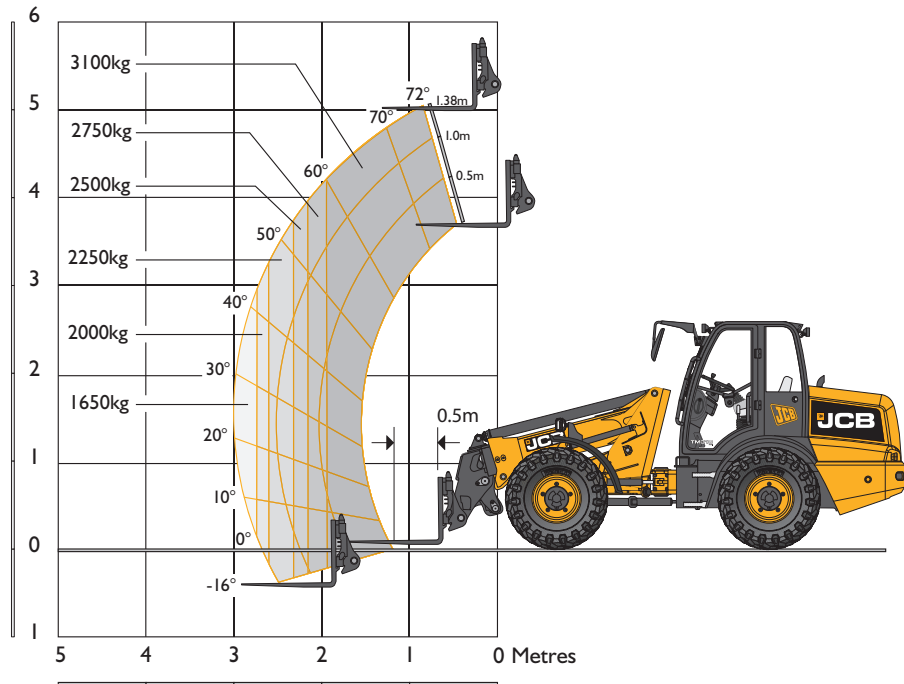

LOADER PERFORMANCE

Machine Model		TM310 & TM310S
Max lift capacity	kg (lb)	3100 (6834)
Lift capacity to full height	kg (lb)	3100 (6834)
Lift capacity at full reach	kg (lb)	1650 (3638)
Lift height	m (ft-in)	5.2 (17-0)
Reach at maximum lift height	m (ft-in)	1.38 (4-6)
Maximum forward reach	m (ft-in)	3.0 (9-10)
Reach with 1 tonne load	m (ft-in)	3.0 (9-10)

ENGINE

Machine Model		TM310	TM310S
Manufacturer		JCB	
Model		Dieselmax	
Displacement	ltr (in ³)	4.4 (269)	
No. of cylinders		4	
Bore size	mm	103	
Stroke	mm	132	
Aspiration		Turbocharged/charge cooled	
Power rating			
Power @ 2200rpm	kW (HP)	97(130)	108 (145)
Torque rating			
Torque @ 1500rpm	Nm(lb ft)	532 (392)	550 (406)

TRANSMISSION

JCB 6 speed transmission incorporating torque converter; 6 speed powershift gearbox with torque lockup in 5th and 6th. 3 operating modes: Eco, Power and Field. Travel speed 40kph (25mph). Transmission kick down.

A combined steering column switch incorporates direction control and 6 forward and 4 reverse powershift gears with auto-select between 4th and 6th in Eco and 3rd and 6th in powershift, direction control also on joystick.

Front and rear drive axles: JCB epicyclic hub reduction drive/axles with Max-Trac torque proportioning differentials.

Permanent 4 wheel drive

BRAKES

Service Brake: Power assisted hydraulic activated, self adjusted, oil immersed in board multi disc front axle brake. Providing braking on all wheels.

Parking Brake: Hand operated disc brake on output shaft of gearbox mounted internally.



BOOM AND CARRIAGE

Boom is manufactured from high tensile steel. Low maintenance, hard wearing pads. One boom end auxiliary hydraulic service fitted as standard.

Pin & cone carriage fitted as standard.

SAFETY

Safety check values fitted to carriage tilt; telescopic and boom lift rams. JCB Adaptive Load Control fitted in compliance with EN1500.

SERVICE CAPACITIES

Fuel Tank	litres (UK gal)	160 (35)
Hydraulic tank	litres (UK gal)	97 (21)
Hydraulic system	litres (UK gal)	135 (29.7)
Engine coolant system	litres (UK gal)	25 (5.5)

HYDRAULICS

Pump type		Variflow piston pump
Pump max flow @ 2200rpm	l/min	140
Pump max pressure	bar (psi)	230 (3336)
Hydraulic cycle times		Seconds
Boom raise		6.0
Boom lower		4.4
Extend		4.0
Retract		2.6
Bucket dump		2.6
Bucket crowd		3.0

Proportional auxiliary control operated by joystick with constant flow setting. End damping on boom lower and retract.

ELECTRICS

System voltage – 12V. Alternator output – 95Ah. Battery capacity – 120Ah. Full roading lighting. Reversing light. Direction indicators. Front Worklights (2 off). Rear Worklights (2 off). Battery Isolator.

STANDARD EQUIPMENT

Bodywork: Recovery hitch, Propshaft guard, Plastic front fenders.

Cab: Rear centrally mounted ROPS and FOPS safety structure. Fully adjustable mechanical suspension seat. Adjustable steering column. Full digital instrumentation including engine & transmission temperature, fuel and speedo. Audible /visual warning panel. Tinted laminated safety glass. Front & rear screen wash/wipe. 3 speed heater with replaceable air filter. LH & RH opening doors. Adjustable single lever hydraulic boom control console. Column mounted single lever transmission selector. Combination stalk controls for lights, wipers, horn, direction indicators. Separate side console for auxiliary switches. Interior light, external rear view mirrors and fire extinguisher as standard. Front screen roller blind, top screen roller blind, interior mirror, standard exterior mirrors, Reverse alarm.

Steering: 43° articulation steering with double acting hydrostatic system. Priority steer valve. Emergency steering via internal hydraulic system in case of power failure.

OPTIONS AND ACCESSORIES

Limited slip differential axles front/rear, air conditioning, smooth ride system, Q-fit Carriage, air suspension seat, additional front & rear working lights; loader boom light, twin reverse light kit; biodegradable oil, sliding door window (LH & RH), quickhitch isolator; hydraulic tow hitch with electrics and hydraulic rear auxiliaries, Scavenge System, top screen guard, tooth guard rotating beacon, exterior deluxe mirror; Attachments: Contact your local dealer for comprehensive range, fire extinguisher; front chassis coverplate, rear chassis front belly plate and front bumper; grease gun, Flexaire auto reverse fan; LiveLink telematics.

Wheels and tyres:

Michelin XMCL 460/70 R24

Michelin XMCL 500/70 R24

Goodyear IT520 460/70 R24

Goodyear IT520 500/70 R24

Goodyear 15.5/80 24 10 PLY

A GLOBAL COMMITMENT TO QUALITY

JCB's total commitment to its products and customers has helped it grow from a one-man business into Britain's largest privately owned manufacturer of backhoe loaders, crawler excavators, wheeled excavators, telescopic handlers, wheeled loaders, dump trucks, rough terrain fork lifts, industrial fork lifts, mini/midi excavators, skid steer loaders, tractors and compaction equipment.

By making constant and massive investments in the latest production technology, the JCB factories have become some of the most advanced in the world.

By leading the field in innovative research and design, extensive testing and stringent quality control, JCB machines have become renowned all over the world for performance, value and reliability.

And with a global sales and service network of more than 650 dealers and agents, we aim to deliver the best customer support in the industry.

Through setting the standards by which others are judged, JCB has become one of the world's most impressive success stories.

